

**CNB 68**

**CNB**

SOLARIS YACHTS SRL

Via Curiel, 49

33 051 Aquileia UD Italy

Tél. : +39 431 91304

[cnb@cnbyachts.com](mailto:cnb@cnbyachts.com)

**CNB**  
YACHT BUILDERS

# CNB 68



The successor to the CNB 66, the new CNB 68 offers the same user-friendliness as her predecessor with an open-plan galley, while optimising the volume of the guest and master cabins. Now equipped with two genuine VIP cabins, a crew cabin and a laundry area, the CNB 68 offers unrivalled features in her category. Taking up the new coachroof profile which was so successful on the CNB 62, Philippe Briand has stretched the lines to achieve a subtle balance between protection and sportiness. Versatile, the CNB 68 can be equipped with a performance rig or, for longer voyages, a carbon arch. The interior design by Jean-Marc Piaton echoes the CNB core values while bringing a real stylistic evolution with more lightness and freshness. The CNB 68 is a high-performance, comfortable and family-friendly sailing yacht. Whether you are sailing with a crew or alone, you will enjoy its immense open-plan interior and all the technical solutions that have been tried and tested on the CNB 62 and CNB 78.

Vincent Arnaud



In designing the CNB 68, we wanted to surpass what we had already achieved with the CNB66. By adding a second chine and optimizing the overall hull and rig parameters, the efficiency along with the seaworthiness are further enhanced, while providing additional living space and comfort both inside and on deck. Without a doubt, the CNB68 will be a worthy successor in the CNB yachts line and the new benchmark for sailing yachts of this size for the years to come.

Philippe Briand



Architect  
Philippe Briand Yacht design

**CNB68** | High performance hull



**The hull**  
Its sleek line with two chines promises performance and comfort at sea.





Interior design  
Piaton Yacht design



This new CNB 68 continues the open spirit of the iconic 66. For this latest model in the range, we wanted to further evolve the interior style, giving it a more contemporary and lighter expression. Every detail, every material has been thought and carefully selected to achieve the highest level of finish, functionality, and «French Elegance» staying true to the brand's DNA.

Jean-Marc Piaton

Saloon



CNB68 | Bright dining area



CNB68 | Spacious saloon with open galley





Starbord lounge area

Galley





Master suite



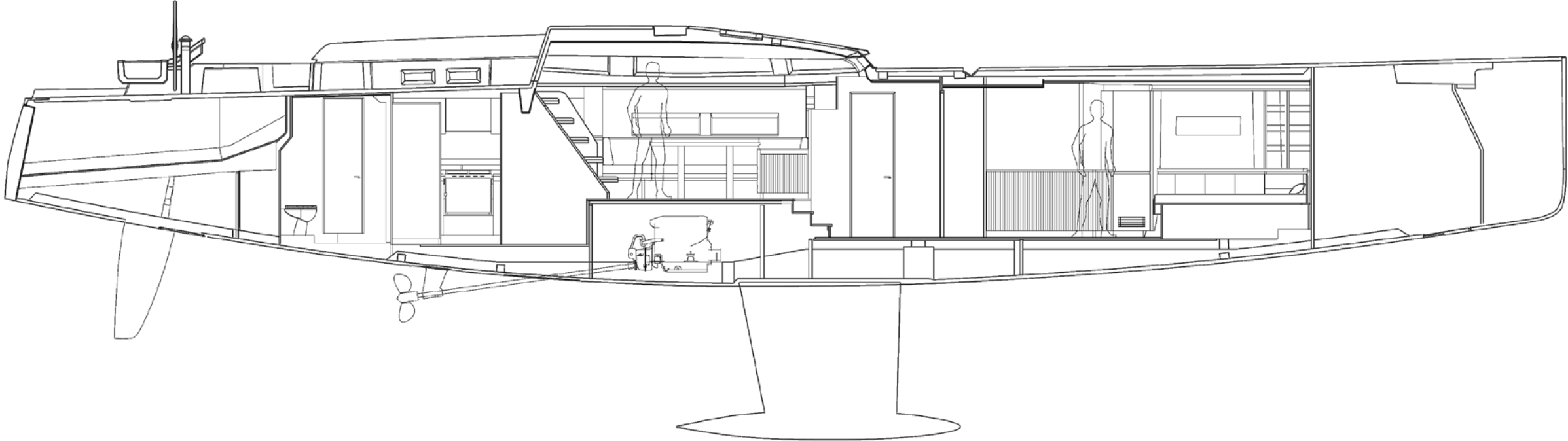
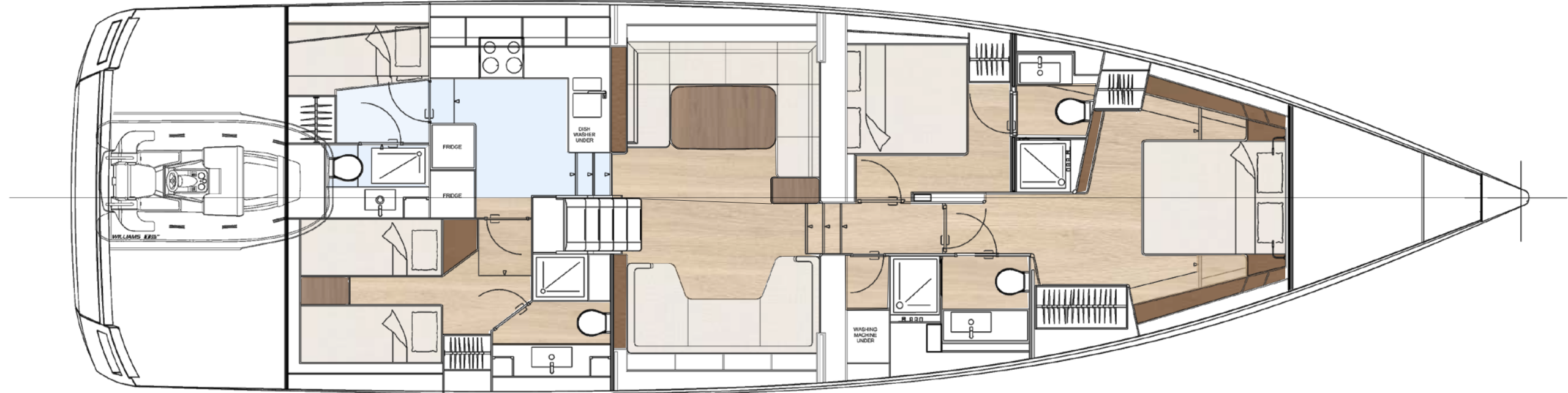



**DESIGN TEAM**

- Naval architect
- Interior design

Philippe Briand  
Jean-Marc Piaton

**DIMENSIONS**

- Length overall (Including bowsprit and transom door)
- Hull length (Only hull as per CE rules)
- Waterline length
- Maximum beam

22,22 m  
20,66 m  
19,30 m  
5,64 m

**DRAFTS**

- Standard full cast iron keel
- Optional weldox keel – lead bulb

3,45 m  
2,50 m / 2,95 m / 3,45 m

**TANKAGE**

- Fresh water capacity
- Fuel capacity

1000 litres  
1200 litres

## CNB68 | Sail plans

### Performance carbon rig

Mainsail	141 m <sup>2</sup>
Furling genoa (108%)	116 m <sup>2</sup>
Jib	96 m <sup>2</sup>
Staysail	54 m <sup>2</sup>
Asymmetrical spinnaker	371 m <sup>2</sup>
Air draft	32.4 m

### Standard aluminium rig

Mainsail	132 m <sup>2</sup>
Furling genoa (108%)	111 m <sup>2</sup>
Jib	91 m <sup>2</sup>
Staysail	53 m <sup>2</sup>
Asymmetrical spinnaker	352 m <sup>2</sup>
Air draft	30.8 m

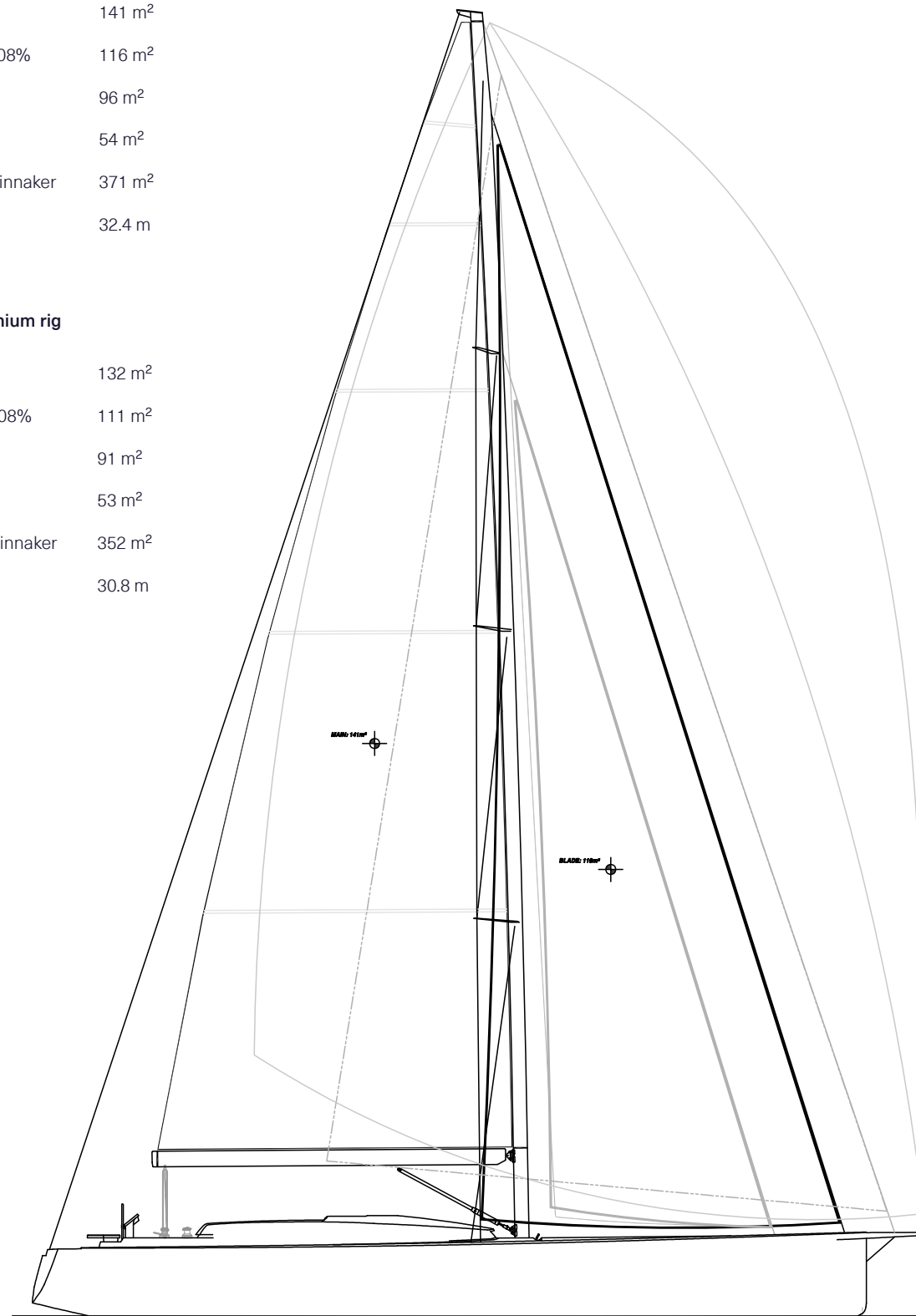

### Standard aluminium rig + arch

Mainsail	132 m <sup>2</sup>
Furling genoa (108%)	114 m <sup>2</sup>
Jib	91 m <sup>2</sup>
Staysail	53 m <sup>2</sup>
Asymmetrical spinnaker	352 m <sup>2</sup>
Air draft	31.5 m

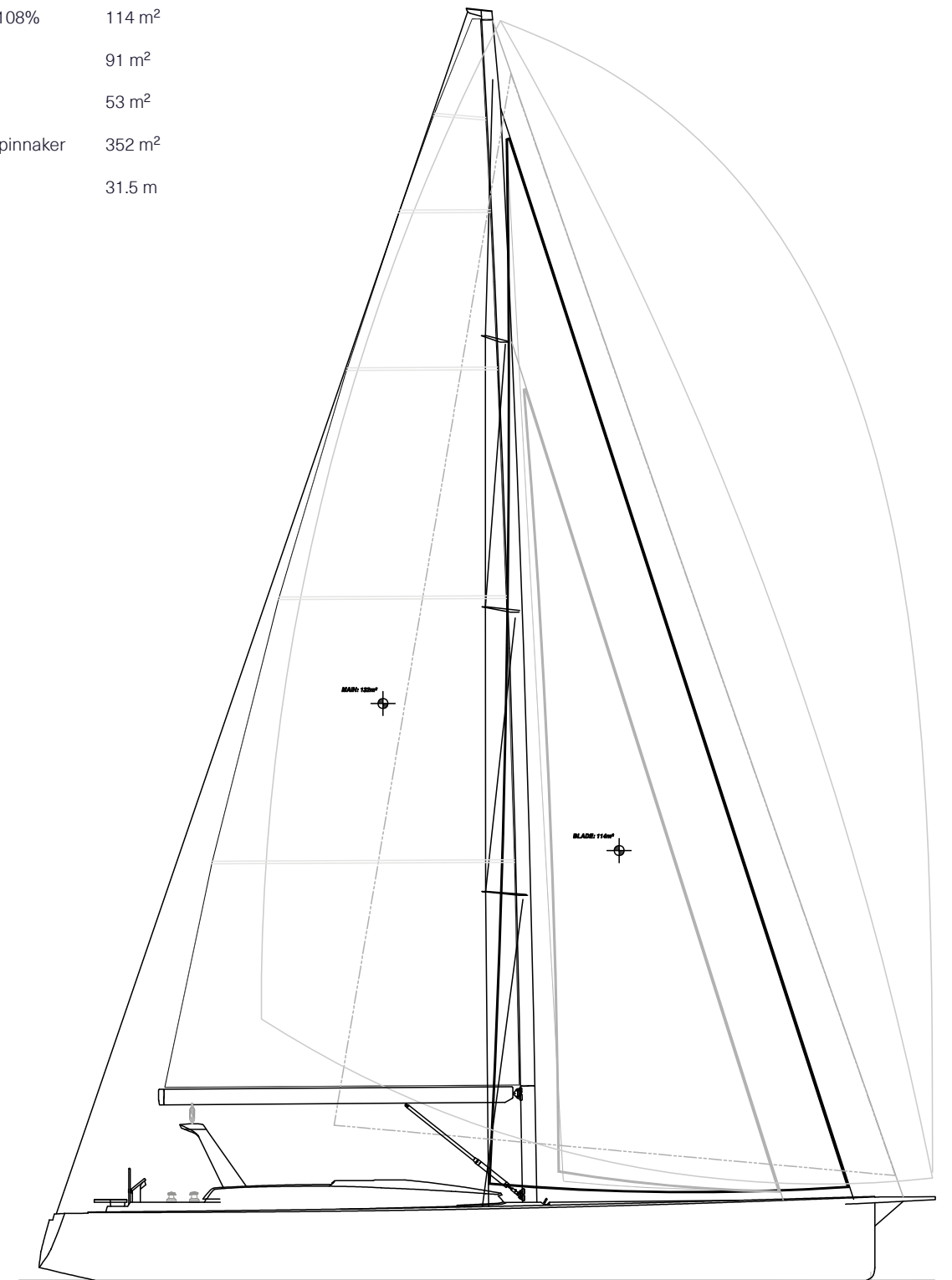



CNB  
68

## CNB 68 - sparkling, spacious and secure

Solaris Yachts SRL

Via Curiel, 49 • 33 051 Aquileia UD Italy

Tél. : +39 431 91304

[cnb@cnbyachts.com](mailto:cnb@cnbyachts.com)

Conception : Piaton et Associés

Rendering : Ycar Renderings

Photo page 5 : Simon Spring

This document is not contractual. The illustrations of the boat featured in this brochure may include optional equipment/accessories.

**CNB**  
YACHT BUILDERS